

# ULTRA®

## Model UL5500

**TOTALSOURCE®**

FEATURED PRODUCTS

- Hard chrome-plated ram and piston
- Self-lubricating bearings at all pivot points
- Large steer wheels with "Ball-thrust" steering
- High tensile steel frame and seamless forks
- Grease fittings
- Full adjustable push rods on forks
- 230° pivot action maneuvers in compact areas
- Spring-a-matic handle self returns
- Only 1 snap ring—4 pins to remove hydraulic unit
- Poly-nylon steer wheels and load rollers standard, for easy quiet travel
- Tapered fork ends and maintenance-free skids for easy entry and exit of pallets
- Painted quality safety color after anti-rust treatment
- Safety designed loop handle, includes neutral position and fingertip release
- Load capacity: 5,500LBS
- Lowered height of forks: 2.9"
- Raised height: 7<sup>3</sup>/<sub>4</sub>"
- Overall width across forks: 27"

- Fork width: 6"
- Space between forks: 15"
- Standard fork lengths: 48"
- Load rollers: 2.9" x 3<sup>5</sup>/<sub>8</sub>"
- Front wheels (steer): 7" x 2"
- Wheels: poly-nylon
- Body length (including pump): 16"
- Load roller axle to end of truck:  
roller down: 6<sup>3</sup>/<sub>4</sub>" roller up: 9<sup>3</sup>/<sub>4</sub>"
- Approximate weight: 202LBS
- 6-month warranty
- Available in USA only

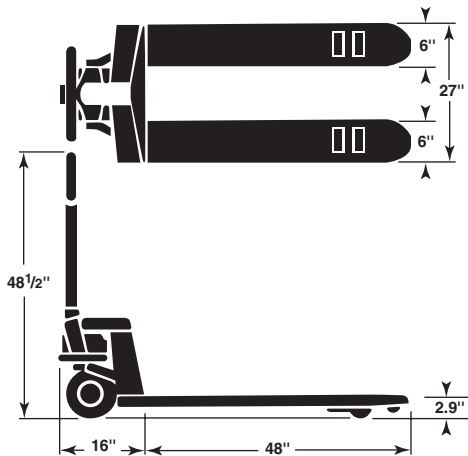

### HAND LOWERING CONTROL—3 POSITIONS

Lifting—neutral—lowering with handle or foot pedal means extra safety. Neutral allows pumping at the most convenient angle to the operator and free handle movement when the truck is in motion. The handle returns automatically to the vertical position.

### BRAKE

Safety spring-loaded loop handle allows load to be lowered while in motion to act as a brake.

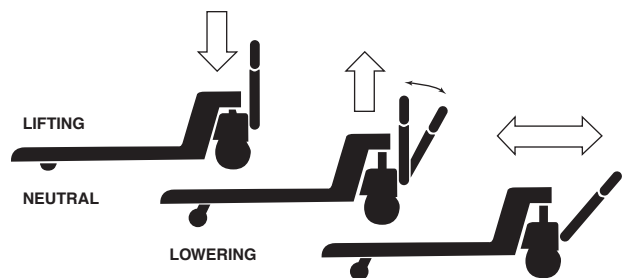

United States  
800 255 4109  
Fax 913 764 7278

International  
913 768 3099  
Fax 913 829 6206

Canada (ONT)  
800 509 7668  
Fax 905 564 5717

Canada (BC)  
888 661 8611  
Fax 604 944 7024

Mexico  
+52 55 5861 8550  
Fax +52 55 5819 3004